

# Product Description

## SALSA® MLPA® Probemix P419-B1 CDKN2A/2B-CDK4

To be used with the MLPA General Protocol.

### Version B1

For complete product history see page 10.

### Catalogue numbers:

- **P419-025R:** SALSA MLPA Probemix P419 CDKN2A/2B-CDK4, 25 reactions.
- **P419-050R:** SALSA MLPA Probemix P419 CDKN2A/2B-CDK4, 50 reactions.
- **P419-100R:** SALSA MLPA Probemix P419 CDKN2A/2B-CDK4, 100 reactions.

To be used in combination with a SALSA MLPA reagent kit and Coffalyser.Net data analysis software. MLPA reagent kits are either provided with FAM or Cy5.0 dye-labelled PCR primer, suitable for Applied Biosystems and Beckman/SCIEX capillary sequencers, respectively (see [www.mrcholland.com](http://www.mrcholland.com)).

### Certificate of Analysis

Information regarding storage conditions, quality tests, and a sample electropherogram from the current sales lot is available at [www.mrcholland.com](http://www.mrcholland.com).

### Precautions and warnings

For professional use only. Always consult the most recent product description AND the MLPA General Protocol before use: [www.mrcholland.com](http://www.mrcholland.com). It is the responsibility of the user to be aware of the latest scientific knowledge of the application before drawing any conclusions from findings generated with this product.

### General information

The SALSA MLPA Probemix P419 CDKN2A/2B-CDK4 is a **research use only (RUO)** assay for the detection of deletions or duplications in the *CDKN2A*, *CDKN2B* and *CDK4* genes, which are associated with familial cutaneous melanoma, neural system tumour- and pancreatic cancer syndromes. This probemix can also be used to detect the presence of a *MITF* p.E318K (c.952G>A) point mutation and the status of codon 24 of the *CDK4* gene with a WT probe.

Malignant melanoma is estimated to be hereditary in 5-10% of the cases. Familial cutaneous melanoma arises in an autosomal-dominant pattern within the affected families, and germline alterations in the *CDKN2A* gene (9p21.3) are detected in up to 40% of cases (Goldstein et al. 2007). The *CDKN2A* gene encodes for two proteins read in alternative reading frames, namely p16<sup>INK4A</sup> and p14<sup>ARF</sup>. The majority of *CDKN2A* mutations detected in familial melanoma patients affect exons 1 and 2, which code for p16<sup>INK4A</sup>. However, exon 1 mutations specific for p14<sup>ARF</sup> have also been reported (Hewitt et al. 2002), as well as larger genomic deletions of *CDKN2A* (Randerson-Moor et al. 2001; Knappskog et al. 2006; Lesueur et al. 2008). Moreover, both heterozygous and homozygous deletions harbouring both *CDKN2A* and *CDKN2B* are frequently detected in somatic melanoma samples (Flores et al. 1996).

Another high-penetrance, but low-frequency, melanoma susceptibility gene is *CDK4* (12q14.1), which is mutated in 2% of the melanoma families (Goldstein et al. 2007). Two point mutations (p.R24H and p.R24K) of *CDK4* have been detected in familial melanoma cases (Zuo et al. 1996). In addition, a germline mutation p.E318K (c.952G>A) in the *MITF* gene has been suggested to associate with predisposition to familial melanoma (Yokoyama et al. 2011; Bertolotto et al. 2011).

**This SALSA MLPA probemix is not CE/FDA registered for use in diagnostic procedures. Purchase of this product includes a limited license for research purposes.**

### Gene structure and transcript variants:

Entrez Gene shows transcript variants of each gene: <http://www.ncbi.nlm.nih.gov/sites/entrez?db=gene>  
Matched Annotation from NCBI and EMBL-EBI (MANE): <https://www.ncbi.nlm.nih.gov/refseq/MANE/> and <http://tark.ensembl.org/>

For NM\_ mRNA reference sequences: <http://www.ncbi.nlm.nih.gov/sites/entrez?db=nucleotide>  
Locus Reference Genomic (LRG) database: <http://www.lrg-sequence.org/>

### Exon numbering

From product description version B1-03 onwards, the exon numbering from the MANE transcripts is used for *CDKN2A*, *CDKN2B* and *CDK4*. Consequently, for *CDKN2A*, the exon numbering has been changed: NM\_000077.5 (MANE Select) encoding p16<sup>INK4A</sup> and NM\_058195.4 (MANE Plus Clinical) encoding p14<sup>ARF</sup> are used. Both NM\_000077.5 and NM\_058195.4 have distinct first exons (both numbered as exon 1) which contain the translation start codon, and share a common second exon, which is translated in different reading frames (see schematic presentation below). The exon numbering (LRG\_11 for *CDKN2A*), used in previous versions of this product description, can be found in between brackets in the schematic presentation below. Please be aware that the MANE and LRG exon numbering do not always correspond, and MANE exon numbering used here may differ from literature. As changes to the databases can occur after release of this product description, the NM\_ sequence and exon numbering may not be up-to-date.

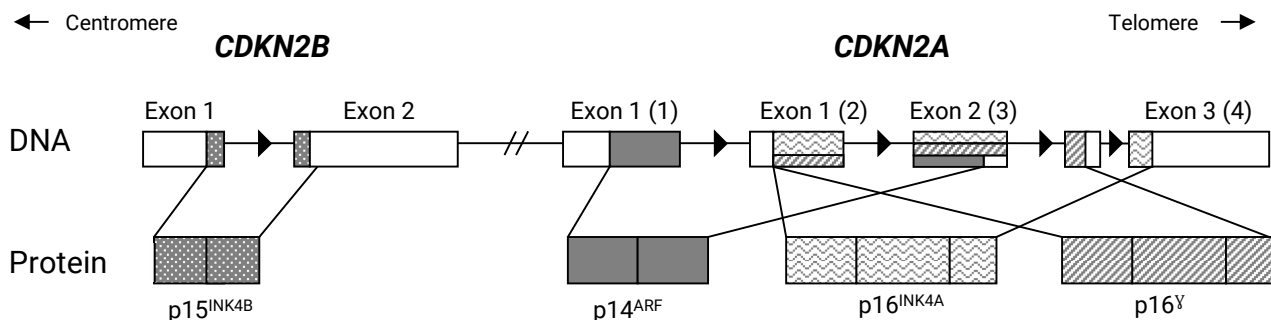

**Schematic presentation 1. *CDKN2A* and *CDKN2B* gene structures and proteins encoded.** Exon 1 of NM\_058195.4 codes the first exon of p14<sup>ARF</sup> protein and exon 1 of NM\_000077.5 codes the first exon of p16<sup>INK4A</sup> protein. An alternative exon (330 nt before exon 3) for *CDKN2A* is present in NM\_001195132.2 transcript variant 5. In this P419 probemix two probes for this alternative exon are included: probe 17807-L22411 at 157 nt and probe 17811-L21945 at 184 nt. The clinical significance of this transcript variant, also known as p16<sup>γ</sup> (Lin et al. 2007) is not yet known. Transcript variant 5 includes an additional exon that causes a frameshift in the 3' coding region when compared to variant 1 (encoding p16<sup>INK4A</sup>). The resulting isoform p16<sup>γ</sup> has a distinct C-terminus, which is longer than p16<sup>INK4A</sup>. However, this transcript is candidate for nonsense-mediated mRNA decay and it is not known if endogenous protein p16<sup>γ</sup> is expressed *in vivo*.

### Probemix content

The SALSA MLPA Probemix P419-B1 *CDKN2A/2B-CDK4* contains 57 MLPA probes with amplification products between 121 and 504 nucleotides (nt). This includes 14 probes for the *CDKN2A* gene, nine probes for the *CDKN2B* gene, nine probes for the *CDK4* gene and 10 flanking probes in total for the *CDKN2A* and *CDKN2B* genes. Furthermore, this probemix contains one probe specific for the *MITF* p.E318K (c.952G>A) point mutation, which will only generate a signal when the mutation is present, and one wildtype probe for *CDK4* codon 24, which will have a drop in signal in case of a *CDK4* codon 24 mutation. In addition, 13 reference probes are included that detect relatively copy number stable regions in various cancer types, including cutaneous melanoma. Complete probe sequences and the identity of the genes detected by the reference probes are available in Table 3 and online ([www.mrcholland.com](http://www.mrcholland.com)).

This probemix contains nine quality control fragments generating amplification products between 64 and 105 nt: four DNA Quantity fragments (Q-fragments), two DNA Denaturation fragments (D-fragments), one Benchmark fragment, one chromosome X and one chromosome Y-specific fragment (see table below). More information on how to interpret observations on these control fragments can be found in the MLPA General Protocol and online at [www.mrcholland.com](http://www.mrcholland.com).

Length (nt)	Name
64-70-76-82	Q-fragments (only visible with <100 ng sample DNA)
88-96	D-fragments (low signal indicates incomplete denaturation)
92	Benchmark fragment
100	X-fragment (X chromosome specific)
105	Y-fragment (Y chromosome specific)

### MLPA technique

The principles of the MLPA technique (Schouten et al. 2002) are described in the MLPA General Protocol ([www.mrcholland.com](http://www.mrcholland.com)). More information on the use of MLPA in tumour applications can be found in Hömig-Hölzel and Savola (2012).

### MLPA technique validation

Internal validation of the MLPA technique using 16 DNA samples from healthy individuals is required, in particular when using MLPA for the first time, or when changing the sample handling procedure, DNA extraction method or instruments used. This validation experiment should result in a standard deviation  $\leq 0.10$  for all probes over the experiment.

### Required specimens

Extracted DNA, which includes DNA derived from paraffin-embedded tissues, free from impurities known to affect MLPA reactions. For more information please refer to the section on DNA sample treatment found in the MLPA General Protocol. More information on the use of FFPE tissue samples for MLPA can be found in Atanesyan et al. (2017).

### Reference samples

A sufficient number ( $\geq 3$ ) of reference samples should be included in each MLPA experiment for data normalisation. All samples tested, including reference DNA samples, should be derived from the same tissue type, handled using the same procedure, and prepared using the same DNA extraction method when possible. For germline testing, reference samples should be derived from different unrelated individuals who are from families without a history of familial cutaneous melanoma, neural system tumour, pancreatic cancer syndromes or other conditions related to the *CDKN2A/2B* or *CDK4* genes, while for somatic testing, reference samples should be derived from healthy individuals without a history of cancer. More information regarding the selection and use of reference samples can be found in the MLPA General Protocol ([www.mrcholland.com](http://www.mrcholland.com)).

### Positive control DNA samples

MRC Holland cannot provide positive DNA samples. Inclusion of a positive sample in each experiment is recommended. Coriell Institute (<https://catalog.coriell.org>) and Leibniz Institute DSMZ (<https://www.dsmz.de/>) have diverse collections of biological resources which may be used as positive control DNA samples in your MLPA experiments. Samples from the Coriell Institute have been tested at MRC-Holland with the P419-B1 probemix and can be used to detect a heterozygous duplication of the 9p21.3 region (NA03226 and NA05067) and the *MITF* p.E318K (c.952G>A) point mutation (HG00259 and HG01498). The following samples from Leibniz Institute DSMZ have been tested at MRC-Holland with the P419-B1 probemix and can be used as positive control samples: ACC-47/DOHH-2 for homozygous deletion of *MTAP*, *CDKN2A/2B* and *DMRTA1*; ACC-264/COLO-679 for subclonal heterozygous deletion of *MLLT3*, *MIR31*, *MTAP*, *CDKN2B* and *DMRTA1* and homozygous deletion of *CDKN2A*, and several other alterations; and ACC-573/SU-DHL-8 for heterozygous gain of *CDK4*. In DSMZ cell line samples some of the reference probes are also affected by CNAs. The quality of cell lines can change; therefore samples should be validated before use.

### SALSA Binning DNA SD008

The SD008 Binning DNA provided with this probemix can be used for binning of all probes including the *MITF* mutation-specific probe (probe 17808-L23191 at 162 nt). SD008 Binning DNA is a mixture of genomic DNA from healthy individuals and plasmid DNA that contains the target sequence detected by the above mentioned probe. Inclusion of one reaction with 5  $\mu$ l SD008 Binning DNA in initial MLPA experiments is essential as it can be used to aid in data binning of the peak pattern using Coffalyser.Net software. Furthermore, Binning DNA should be included in the experiment whenever changes have been applied to the set-up of the capillary electrophoresis device (e.g. when capillaries have been renewed). Binning DNA should never be used as a reference sample in the MLPA data analysis, neither should it be used for quantification of mutation signals. It is strongly advised that all samples tested are extracted with the same method and derived from the same source of tissue. For further details, please consult the SD008 Binning DNA product description, available online: [www.mrcholland.com](http://www.mrcholland.com). **This product is for research use only (RUO).**

### Data analysis

Coffalyser.Net software should be used for data analysis in combination with the appropriate lot-specific MLPA Coffalyser sheet. For both, the latest version should be used. Coffalyser.Net software is freely downloadable at [www.mrcholland.com](http://www.mrcholland.com). Use of other non-proprietary software may lead to inconclusive or false results. For more details on MLPA quality control and data analysis, including normalisation, see the Coffalyser.Net Reference Manual.

### Interpretation of results

The standard deviation of each individual probe over all the reference samples should be  $\leq 0.10$  and the final ratio (FR) of each individual reference probe in the patient samples should be between 0.80 and 1.20 for germline testing. When these criteria are fulfilled, the following cut-off values for the FR of the probes can be used to interpret MLPA results for autosomal chromosomes or pseudo-autosomal regions:

Copy number status	Final ratio (FR)
Normal	$0.80 < FR < 1.20$
Homozygous deletion	FR = 0
Heterozygous deletion	$0.40 < FR < 0.65$
Heterozygous duplication	$1.30 < FR < 1.65$
Heterozygous triplication/homozygous duplication	$1.75 < FR < 2.15$
Ambiguous copy number	All other values

Note: The term “dosage quotient”, used in older product description versions, has been replaced by “final ratio” to become consistent with the terminology of the Coffalyser.Net software. (Calculations, cut-offs and interpretation remain unchanged.) Please note that the Coffalyser.Net software also shows arbitrary borders as part of the statistical analysis of results obtained in an experiment. As such, arbitrary borders are different from the final ratio cut-off values shown here above.

**Please note that these above mentioned final ratios are only valid for germline testing. Final ratios are affected both by percentage of tumour cells and by possible subclonality.**

- Arranging probes according to chromosomal location facilitates interpretation of the results and may reveal more subtle changes such as those observed in mosaic or subclonal cases. Analysis of parental samples may be necessary for correct interpretation of complex results of hereditary cases.
- False positive results: Please note that abnormalities detected by a single probe (or multiple consecutive probes) still have a considerable chance of being a false positive result. Sequence changes (e.g. SNVs, point mutations) in the target sequence detected by a probe can be one cause. Incomplete DNA denaturation (e.g. due to salt contamination) can also lead to a decreased probe signal, in particular for probes located in or near a GC-rich region or in or near the *CDK4* gene. The use of an additional purification step or an alternative DNA extraction method may resolve such cases. Additionally, contamination of DNA samples with cDNA or PCR amplicons of individual exons can lead to an increased probe signal (Varga et al. 2012). Analysis of an independently collected secondary DNA sample can exclude these kinds of contamination artefacts.
- Normal copy number variation in healthy individuals is described in the database of genomic variants: <http://dgv.tcag.ca/dgv/app/home>. Users should always consult the latest update of the database and scientific literature when interpreting their findings.
- Not all abnormalities detected by MLPA are pathogenic. In some genes, intragenic deletions are known that result in very mild or no disease (as described for *DMD* by Schwartz et al. 2007). For many genes, more than one transcript variant exists. Copy number changes of exons that are not present in all transcript variants may not have clinical significance. Duplications that include the first or last exon of a gene (e.g. exons 1-3) might not result in inactivation of that gene copy.
- Copy number changes detected by reference probes or flanking probes are unlikely to have any relation to the condition tested for.
- False results can be obtained if one or more peaks are off-scale. For example, a duplication of one or more exons can be obscured when peaks are off-scale, resulting in a false negative result. The risk on off-scale

peaks is higher when probemixes are used that contain a relatively low number of probes. Coffalyser.Net software warns for off-scale peaks while other software does not. If one or more peaks are off-scale, rerun the PCR products using either: a lower injection voltage or a shorter injection time, or a reduced amount of sample by diluting PCR products.

#### P419-specific note

- In samples from tumour tissues, reference probes are more prone to have deviating copy number results as compared to blood derived germline samples. When regions targeted by reference probes are affected by copy number alterations, it can help to turn the slope correction off in Coffalyser.Net analysis to get the correct copy number interpretation on the target region.

#### Limitations of the procedure

- In most populations, the major cause of genetic germline defects in the *CDKN2A*, *CDKN2B* and *CDK4* are small (point) mutations, most of which will not be detected by using SALSA MLPA Probemix P419 CDKN2A/2B-CDK4. Likewise, most genetic alterations observed in somatic samples are small (point) mutations. If present, these type of mutations in the *CDKN2A*, *CDKN2B* and *CDK4* genes will not be detected by using SALSA MLPA Probemix P419.
- MLPA cannot detect any changes that lie outside the target sequence of the probes and will not detect copy number neutral inversions or translocations. Even when MLPA did not detect any aberrations, the possibility remains that biological changes in that gene or chromosomal region *do* exist but remain undetected.
- Sequence changes (e.g. SNVs, point mutations) in the target sequence detected by a probe can cause false positive results. Mutations/SNVs (even when >20 nt from the probe ligation site) can reduce the probe signal by preventing ligation of the probe oligonucleotides or by destabilising the binding of a probe oligonucleotide to the sample DNA.
- MLPA analysis on tumour samples provides information on the *average* situation in the cells from which the DNA sample was purified. Gains or losses of genomic regions or genes may not be detected if the percentage of tumour cells is low. In addition, subclonality of the aberration affects the final ratio of the corresponding probe. Furthermore, there is always a possibility that one or more reference probes *do* show a copy number alteration in a patient sample, especially in solid tumours with more chaotic karyotypes.

#### Confirmation of results

Copy number changes detected by only a single probe always require confirmation by another method. An apparent deletion detected by a single probe can be due to e.g. a mutation/polymorphism that prevents ligation or destabilises the binding of probe oligonucleotides to the DNA sample. Sequence analysis can establish whether mutations or polymorphisms are present in the probe target sequence. The finding of a heterozygous mutation or polymorphism indicates that two different alleles of the sequence are present in the sample DNA and that a false positive MLPA result was obtained.

Copy number changes detected by more than one consecutive probe should be confirmed by another independent technique such as long range PCR, qPCR, array CGH or Southern blotting, whenever possible. Deletions/duplications of more than 50 kb in length can often be confirmed by FISH.

#### LOVD and COSMIC mutation databases

*CDKN2A* database (LOVD) - <https://databases.lovd.nl/shared/genes/CDKN2A>

*CDKN2B* database (LOVD) - <https://databases.lovd.nl/shared/genes/CDKN2B>

*CDK4* database (LOVD) - <https://databases.lovd.nl/shared/genes/CDK4>

COSMIC database for somatic mutations in cancer - <https://cancer.sanger.ac.uk/cosmic>

We strongly encourage users to deposit positive results in the LOVD and COSMIC. Recommendations for the nomenclature to describe deletions/duplications of one or more exons can be found on <http://varnomen.hgvs.org/>.

Please report false positive results due to SNVs and unusual results (e.g. a deletion of *CDKN2A* exons 1 and 3 but not exon 2) to MRC Holland: [info@mrcholland.com](mailto:info@mrcholland.com).

**Table 1. SALSA MLPA Probemix P419-B1 CDKN2A/2B-CDK4**

Length (nt)	SALSA MLPA probe	Chromosomal position (hg18) <sup>a</sup>			
		Reference	CDKN2A	CDKN2B	CDK4
64-105	Control fragments – see table in probemix content section for more information				
121	Reference probe 19616-L27455	4p13			
128	Reference probe 21566-L30677	18q21			
132	<b>CDKN2B probe</b> 22023-L30944			Exon 2	
140	<b>CDKN2B probe</b> 11867-L23435			Exon 1	
145	Reference probe 14199-L22409	2q13			
151	<b>CDK4 probe</b> 03173-L22410				Exon 3
157 ∅	<b>CDKN2A probe</b> 17807-L22411		Intron 2		
162 §	<b>MITF probe</b> 17808-L23191				<b>p.E318K</b> (c.952G>A)
166	<b>CDK4 probe</b> 17809-L21943				Exon 2
172	Reference probe 12741-L21983	21q22			
178	<b>CDK4 probe</b> 17810-L21944				Exon 1
184 ∅	<b>CDKN2A probe</b> 17811-L21945		Intron 2		
190 «	<b>CDK4 probe</b> 17812-L23573				Exon 6
196	Reference probe 05268-L30942	2p22			
202 ~	<b>MLLT3 probe</b> 01287-L23185				9p21.3
208	<b>CDKN2B probe</b> 16066-L23293			Exon 1	
216 ∞ Ж	<b>CDK4 probe</b> 17813-SP0552-L22575				<b>WT codon 24</b>
222	<b>CDKN2B probe</b> 11871-L22416			Exon 1	
229	<b>CDKN2B probe</b> 16059-L18233			Exon 2	
236	<b>CDKN2A probe</b> 21912-L19021		Exon 3		
242	<b>CDKN2A probe</b> 01289-L31535		Exon 1		
250	Reference probe 18056-L31125	16q23			
256	<b>CDKN2A probe</b> 16060-L31124		Intron 1		
263	<b>CDKN2A probe</b> 15674-L31123		Exon 2		
269	<b>CDKN2A probe</b> 15675-L31122		Downstream		
275 «	<b>CDK4 probe</b> 17735-L31121				Exon 8
283	<b>CDKN2A probe</b> 01291-L22469		Exon 3		
288	Reference probe 08834-L30725	2p13			
294 ~	<b>DMRTA1 probe</b> 18242-L23192				9p21.3
301 ~	<b>MTAP probe</b> 15677-L21991				9p21.3
307 ~	<b>TMC1 probe</b> 08987-L23572				9q21.13
314	Reference probe 17876-L23179	19q13			
319 ~	<b>MTAP probe</b> 01293-L22907				9p21.3
328 ~	<b>MTAP probe</b> 01294-L13278				9p21.3
335	Reference probe 09776-L23522	15q15			
341	<b>CDKN2A probe</b> 14004-L31117		Exon 1		
349 ~	<b>DMRTA1 probe</b> 18243-L23511				9p21.3
357	<b>CDK4 probe</b> 17815-L23512				Exon 4
364	<b>CDKN2A probe</b> 21951-L30767		Exon 2		
373	<b>CDKN2B probe</b> 15992-L23660			Upstream	
379	Reference probe 05288-L23294	14q22			
385	<b>CDKN2A probe</b> 17817-L23295		Exon 2		
394	<b>CDKN2A probe</b> 08659-L30724		Exon 1		
400 «	<b>CDK4 probe</b> 21952-L30768				Exon 7
409	<b>CDKN2B probe</b> 03814-L03851			Exon 1	
418 «	<b>CDK4 probe</b> 21950-L30943				Exon 8
425	<b>CDKN2A probe</b> 15680-L30801		Exon 1		
432 ~	<b>PTENP1 probe</b> 17311-L23180				9p13.3
440 ~	<b>MTAP probe</b> 17819-L23181				9p21.3
448	<b>CDKN2B probe</b> 17820-L23182			Exon 2	

Length (nt)	SALSA MLPA probe	Chromosomal position (hg18) <sup>a</sup>				
		Reference	CDKN2A	CDKN2B	CDK4	Other
454	Reference probe 09107-L21996	4q25				
463	<b>CDKN2B probe</b> 17821-L21955			Exon 2		
470 ~	<b>MIR31 probe</b> 13665-L22879					9p21.3
477	Reference probe 14956-L31118	6q22				
483 «	<b>CDK4 probe</b> 21953-L30769				Exon 5	
490	<b>CDKN2A probe</b> 12475-L30941		Upstream			
504	Reference probe 21229-L30802	10p11				

<sup>a</sup> See section Exon numbering on page 2 for more information.

§ Mutation-specific probe. This probe will only generate a signal when the *MITF* p.E318K (c.952G>A) mutation is present.

∞ Wild type sequence detected. A lowered probe signal can be due to a mutation in codon 24 of *CDK4*. Other variants near the ligation site can also cause a lowered signal. A positive result must be confirmed by another method.

« Probe located in or near a GC-rich region. A low signal can be caused by salt contamination in the DNA sample leading to incomplete DNA denaturation, especially of GC-rich regions.

Ж This probe consists of three parts and has two ligation sites. A low signal of this probe can be due to depurination of the sample DNA, e.g. due to insufficient buffering capacity or a prolonged denaturation time. When this occurs in reference samples, it can look like an increased signal in the test samples.

~ Flanking probe. Included to help determine the extent of a deletion/duplication. Copy number alterations of only the flanking or reference probes are unlikely to be related to the condition tested.

∅ This probe targets an alternative exon present in NM\_001195132.2 transcript variant 5, also known as p16<sup>γ</sup>. Clinical and/or diagnostic significance of copy number alterations in this alternative exon is not yet known, please see Schematic representation 1 and the note below this figure on page 2 for further information.

SNVs located in the target sequence of a probe can influence probe hybridization and/or probe ligation. Single probe aberration(s) must be confirmed by another method.

**Table 2a. CDKN2A and CDKN2B probes arranged according to chromosomal location**

Length (nt)	SALSA MLPA probe	Gene (exon) <sup>a</sup>	Chromosomal band (hg18) / Ligation site	Partial sequence <sup>b</sup> (24 nt adjacent to ligation site)	Distance to next probe
202 ~	01287-L23185	<i>MLLT3</i>	9p21.3	GGTCCGAGCAC-AGTAACATACAG	891.4 kb
470 ~	13665-L22879	<i>MIR31</i>	9p21.3	GTCCTTCGTGTA-TTGCTGTGTATG	290.7 kb
328 ~	01294-L13278	<i>MTAP</i> , ex 1	NM_002451.4; 123-122 reverse	GGTGGTGGTGCC-AGAGGCCATGTC	35.2 kb
440 ~ #	17819-L23181	<i>MTAP</i> , ex 5	NM_002451.4; 502-503	TGGAAGTCATTC-TTGTCAGAGAGG	16.8 kb
319 ~	01293-L22907	<i>MTAP</i> , ex 6	NM_002451.4; 725-726	GAGGTGGTTCTT-GCTAAGGAGGCT	4.5 kb
301 ~ #	15677-L21991	<i>MTAP</i> , ex 7	NM_002451.4; 825-826	ACCGGGTCTTAA-AGACCCTGAAAG	108.2 kb
269	15675-L31122	<b>CDKN2A</b> , down	NM_000077.5 & NM_058195.4; 182 nt after ex 3	TGAAATGCGGTT-AAAATGATGAAT	0.5 kb
236	21912-L19021	<b>CDKN2A</b> , ex 3	NM_000077.5; 656-657 NM_058195.4; 730-731	CCTTTTAACGTA-GATATATGCCTT	0.1 kb
283	01291-L22469	<b>CDKN2A</b> , ex 3	NM_000077.5; 510-511 NM_058195.4; 584-585	TGAAAGAACCAG-AGAGGCTCTGAG	0.4 kb
		stop codon	499-501 (ex 3) of NM_000077.5		
157 ∅	17807-L22411	<b>CDKN2A</b> , int 2	NM_000077.5 & M_058195.4; 358 nt before ex 3; NM_001195132.2; 658-659	GGGAAAGGCCAC-ATCTTCACGCCT	0.1 kb
184 ∅	17811-L21945	<b>CDKN2A</b> , int 2	NM_000077.5 & M_058195.4; 446 nt before ex 3; NM_001195132.2; 570-571	AGGCCAGAGCC-TGAGGCGCCCTT	2.3 kb
385	17817-L23295	<b>CDKN2A</b> , ex 2	NM_000077.5; 430-431 NM_058195.4; 504-505	TGCGCGCGGCTG-CGGGGGGCACCA	0.2 kb
		stop codon	458-460 (ex 2) of NM_058195.4		
364 #	21951-L30767	<b>CDKN2A</b> , ex 2	NM_000077.5; 273-272 reverse NM_058195.4; 347-346 reverse	GCGTCGTGCACG-GGTCGGGTGAGA	0.1 kb
263	15674-L31123	<b>CDKN2A</b> , ex 2	NM_000077.5 & NM_058195.4; 45 nt before ex 2	TCCTTCCGTCA-TGCCGGCCCCCA	3.5 kb
242	01289-L31535	<b>CDKN2A</b> , ex 1	NM_000077.5; 158-157 reverse NM_058195.4; 3.5 kb before ex 2	TCCGACCGTAAC-TATTCGGTGCGT	0.2 kb

Length (nt)	SALSA MLPA probe	Gene (exon) <sup>a</sup>	Chromosomal band (hg18) / Ligation site	Partial sequence <sup>b</sup> (24 nt adjacent to ligation site)	Distance to next probe
		start codon	31-33 (ex 1) of NM_000077.5		
394	08659-L30724	<i>CDKN2A</i> , ex 1	NM_000077.5; 71 nt before ex 1 NM_058195.4; 3.7 kb before ex 2	GCACCGGAGGAA-GAAAGAGGAGGG	0.1 kb
256	16060-L31124	<i>CDKN2A</i> , int 1	NM_000077.5; 138 nt before ex 1 NM_058195.4; 3.8 kb before ex 2	GCCTGGAAAGAT-ACCGCGGTCCCT	19.3 kb
341	14004-L31117	<i>CDKN2A</i> , ex 1	NM_000077.5; 19.4 kb before ex 1 NM_058195.4; 92-93	TGACCCTCCGGA-TTCGGCGCGCGT	0.1 kb
		start codon	62-64 (ex 1) of NM_058195.4		
425	15680-L30801	<i>CDKN2A</i> , ex 1	NM_000077.5; 19.6 kb before ex 1 NM_058195.4; 23 nt before ex 1	AGTCTGCAGTTA-AGGGGGCAGGAG	0.2 kb
490	12475-L30941	<i>CDKN2A</i> , up	NM_000077.5; 19.7 kb before ex 1 NM_058195.4; 175 nt before ex 1	CGCAGGGCTCAG-AGCCGTTCCGAG	8.4 kb
448	17820-L23182	<i>CDKN2B</i> , ex 2	NM_004936.4; 3776-3777	GACATTACCAAG-GTTTGTACAAAT	1.9 kb
463	17821-L21955	<i>CDKN2B</i> , ex 2	NM_004936.4; 1923-1924	TCAGGTGCAGA-GGTCAGACTAAG	1.0 kb
229	16059-L18233	<i>CDKN2B</i> , ex 2	NM_004936.4; 899-900	GCCTGTCTGAGA-CTCACAGGAAGG	0.2 kb
		stop codon	767-769 (ex 2)		
132 #	22023-L30944	<i>CDKN2B</i> , ex 2	NM_004936.4; 691-690 reverse	ACGGGCAGACGA-CCCCAGGCATCG	2.8 kb
409	03814-L03851	<i>CDKN2B</i> , ex 1	NM_004936.4; 462-463	CCTGGAAGCCGG-CGCGGATCCCAA	0.1 kb
		start codon	353-355 (ex 1)		
140	11867-L23435	<i>CDKN2B</i> , ex 1	NM_004936.4; 319-320	CCAACGGTGGAT-TATCCGGGCCGC	0.1 kb
222	11871-L22416	<i>CDKN2B</i> , ex 1	NM_004936.4; 252-253	TCCTAGGAAGGA-GAGAGTGCGCCG	0.3 kb
208	16066-L23293	<i>CDKN2B</i> , ex 1	NM_004936.4; 91 nt before ex 1	CCTCCGCGGAT-CACAGCGGACAG	0.1 kb
373	15992-L23660	<i>CDKN2B</i> , up	NM_004936.4; 163 nt before ex 1	GTCTCTGGCGCA-TGCGTCTAGCA	437.6 kb
294 ~	18242-L23192	<i>DMRTA1</i> , ex 1	9p21.3	GCGGTCAGCGCA-CTTCCACTTGG	4.4 kb
349 ~	18243-L23511	<i>DMRTA1</i> , ex 2	9p21.3	GGCTAGAAGGCA-TTCTACGGTTCT	11.2 Mb
432 ~	17311-L23180	<i>PTENP1</i>	9p13.3	CAAATCTAATTA-CAGAGTTGCGCA	40.9 Mb
307 ~	08987-L23572	<i>TMC1</i>	9q21.13	ATTCTGAGGTT-TCTGGCTAACTT	-

~ Flanking probe. Included to help determine the extent of a deletion/duplication. Copy number alterations of only the flanking or reference probes are unlikely to be related to the condition tested.

∅ This probe targets an alternative exon present in NM\_001195132.2 transcript variant 5, also known as p16 $\gamma$ . Clinical and/or diagnostic significance of copy number alterations in this alternative exon is not yet known, please see Schematic representation 1 and the note below this figure on page 2 for further information.

# This probe's specificity relies on a single nucleotide difference compared to a related gene or pseudogene. As a result, an apparent duplication of only this probe can be the result of a non-significant single nucleotide sequence change in the related gene or pseudogene.

**Table 2b. *CDK4* probes arranged according to chromosomal location**

Length (nt)	SALSA MLPA probe	Gene (exon) <sup>a</sup>	Chromosomal band (hg18) / Ligation site	Partial sequence <sup>b</sup> (24 nt adjacent to ligation site)	Distance to next probe
275 «	17735-L31121	<i>CDK4</i> , ex 8	NM_000075.4; 1157-1158	TCTCTGAGGCTA-TGGAGGGTCCTC	0.2 kb
		stop codon	1065-1067 (ex 8)		
418 «	21950-L30943	<i>CDK4</i> , ex 8	NM_000075.4; 976-977	CTCCCCTCAGGA-AATGCTGACTTT	0.6 kb
400 «	21952-L30768	<i>CDK4</i> , ex 7	NM_000075.4; 959-960	GAGGAGTCGGGA-GCACAGCTGCTG	0.3 kb
190 «	17812-L23573	<i>CDK4</i> , ex 6	NM_000075.4; 827-828	GACCAGTTGGGC-AAAATCTTTGAG	1.3 kb
483 «	21953-L30769	<i>CDK4</i> , ex 5	NM_000075.4; 689-690	GTTGTTACTACTC-TGGTACCGAGCT	0.2 kb
357	17815-L23512	<i>CDK4</i> , ex 4	NM_000075.4; 644-645	GGCCTGGCCAGA-ATCTACAGCTAC	0.3 kb
151	03173-L22410	<i>CDK4</i> , ex 3	NM_000075.4; 433-434	AACCCTGGTGTT-TGAGCATGTAGA	0.3 kb
166	17809-L21943	<i>CDK4</i> , ex 2	NM_000075.4; 303-304	GAGGAGGCCTTC-CCATCAGCACAG	0.1 kb
216 ∞ Ж	17813-SP0552-L22575	<i>CDK4</i> , ex 2	<b>WT for codon 24</b> NM_000075.4; 225-224 and 197-196 reverse	GTGGGGATCACG-28nt spanning oligo-ACACCAATTTC	0.7 kb
		start codon	156-158 (ex 2)		
178	17810-L21944	<i>CDK4</i> , ex 1	NM_000075.4; 74 nt before ex 1	TCCGCGTTCGC-CCC GCCCTCCCA	-

∞ Wild type sequence detected. The presence of the *CDK4* codon 24 mutation will result in a decreased probe signal. Other variants near the ligation site can also cause a lowered signal. A positive result must be confirmed by another method.



⚠ This probe consists of three parts and has two ligation sites. A low signal of this probe can be due to depurination of the sample DNA, e.g. due to insufficient buffering capacity or a prolonged denaturation time.

« Probe located in or near a GC-rich region. A low signal can be caused by salt contamination in the DNA sample leading to incomplete DNA denaturation, especially of GC-rich regions.

**Table 2c. *MITF* probe**

Length (nt)	SALSA MLPA probe	MITF point mutation	Ligation site	Partial sequence <sup>b</sup> (24 nt adjacent to ligation site)	Distance to next probe
162 §	17808-L23191	p.E318K (c.952G>A)	NM_000248.4; 1083-1084	TCATCAAGCAAA-AACCCGTTCTTG	-

§ Mutation-specific probe. This probe will only generate a signal when the *MITF* p.E318K (c.952G>A) mutation is present. It has been tested on artificial DNA and on positive cell line samples listed on page 3.

<sup>a</sup> See section Exon numbering on page 2 for more information.

<sup>b</sup> Only partial probe sequences are shown. Complete probe sequences are available at [www.mrcholland.com](http://www.mrcholland.com). Please notify us of any mistakes: [info@mrcholland.com](mailto:info@mrcholland.com).

SNVs located in the target sequence of a probe can influence probe hybridization and/or probe ligation. Single probe aberration(s) must be confirmed by another method.

**Table 3. Reference probes arranged according to chromosomal location.**

Length (nt)	SALSA MLPA probe	Gene	Chromosomal band (hg18)	Partial sequence (24 nt adjacent to ligation site)	Location (hg18) in kb
196	05268-L30942	<i>SPAST</i>	2p22	GGACGTCTATAA-TGACAGTACTAA	02-032,177
288	08834-L30725	<i>DYSF</i>	2p13	TATTATCTGGAA-TACCAGAGATGT	02-071,750
145	14199-L22409	<i>EDAR</i>	2q13	GAGAGTTCTGTG-GGTGGAGAGAAG	02-108,894
121	19616-L27455	<i>ATP8A1</i>	4p13	CAGATTCTTCTT-CGAGGAGCTCAG	04-042,278
454	09107-L21996	<i>CFI</i>	4q25	ACGATGCATGTA-TCATTAGGTTGG	04-110,887
477	14956-L31118	<i>LAMA2</i>	6q22	GAATGCTGTATG-TTGGTGGGTTAC	06-129,868
504	21229-L30802	<i>CCDC7</i>	10p11	ATCGCCTTAAAC-AGAGGTCTAAAT	10-032,800
379	05288-L23294	<i>ATL1</i>	14q22	AAGCTAACAATT-TAGCAGCCGTGG	14-050,160
335	09776-L23522	<i>SPG11</i>	15q15	TCAGCAGAACAA-ATGGCCCTTCT	15-042,700
250	18056-L31125	<i>PLCG2</i>	16q23	GATCCAGCAGTA-CTTCCCATCCAA	16-080,518
128	21566-L30677	<i>DCC</i>	18q21	GAGTTGTGGCTT-ACAATGAATGGG	18-048,959
314	17876-L23179	<i>SLC7A9</i>	19q13	CCTAAGACCACC-AGTCTCCAAAAG	19-038,051
172	12741-L21983	<i>RIPK4</i>	21q22	AAGCCAAGAAGA-TGGAGATGGCCA	21-042,050

Complete probe sequences are available at [www.mrcholland.com](http://www.mrcholland.com).

### Related SALSA MLPA probemixes

- **ME024 9p21 CDKN2A/2B region:** Contains probes for detection of methylation and/or copy number status of the chromosomal region 9p21.3 (*CDKN2A/2B*, *CDKN2B-AS1*, *MTAP*, *MIR31*, and *PAX5*).
- **ME042 CpG Island methylator phenotype (CIMP):** Contains four probes for the detection of methylation status of the *CDKN2A* gene.

### References

- Atanesyan L et al. (2017). Optimal fixation conditions and DNA extraction methods for MLPA analysis on FFPE tissue-derived DNA. *Am J Clin Pathol.* 147:60-8.
- Bertolotto C et al. (2011). A SUMOylation-defective MITF germline mutation predisposes to melanoma and renal carcinoma. *Nature.* 480:94-8.
- Flores JF et al. (1996). Loss of the p16INK4a and p15INK4b genes, as well as neighboring 9p21 markers, in sporadic melanoma. *Cancer Res.* 56:5023-32.
- Goldstein AM et al. (2007). Features associated with germline CDKN2A mutations: a GenoMEL study of melanoma-prone families from three continents. *J Med Genet.* 44:99-106.

- Hewitt C et al. (2002). Germline mutation of ARF in a melanoma kindred. *Hum Mol Gen.* 11:1273-9.
- Hömig-Hölzel C and Savola S. (2012). Multiplex ligation-dependent probe amplification (MLPA) in tumor diagnostics and prognostics. *Diagn Mol Pathol.* 21:189-206.
- Knappskog S et al. (2006). A novel type of deletion in the CDKN2A gene identified in a melanoma-prone family. *Genes Chromosomes Cancer.* 45:1155-63.
- Lesueur F et al. (2008). The contribution of large genomic deletions at the CDKN2A locus to the burden of familial melanoma. *Br J Cancer.* 99:364-70.
- Lin YC et al. (2007). Human p16gamma, a novel transcriptional variant of p16(INK4A), coexpresses with p16(INK4A) in cancer cells and inhibits cell-cycle progression. *Oncogene.* 26:7017-27.
- Randerson-Moor JA et al. (2001). A germline deletion of p14(ARF) but not CDKN2A in a melanoma-neural system tumour syndrome family. *Hum Mol Gen.* 10:55-62.
- Schouten JP et al. (2002). Relative quantification of 40 nucleic acid sequences by multiplex ligation-dependent probe amplification. *Nucleic Acids Res.* 30:e57.
- Schwartz M et al. (2007). Deletion of exon 16 of the dystrophin gene is not associated with disease. *Hum Mutat.* 28:205.
- Varga RE et al. (2012). MLPA-based evidence for sequence gain: pitfalls in confirmation and necessity for exclusion of false positives. *Anal Biochem.* 421:799-801.
- Yokoyama S et al. (2011). A novel recurrent mutation in MITF predisposes to familial and sporadic melanoma. *Nature.* 480:99-103.
- Zuo L et al. (1996). Germline mutations in the p16INK4a binding domain of CDK4 in familial melanoma. *Nat Genet.* 12:97-9.

### Selected publications using SALSA MLPA Probemix P419 CDKN2A/2B-CDK4

- Betti M et al. (2016). CDKN2A and BAP1 germline mutations predispose to melanoma and mesothelioma. *Cancer Lett.* 378:120-30.
- Gingras MC et al. (2021). Sequencing of a central nervous system tumor demonstrates cancer transmission in an organ transplant. *Life Sci Alliance.* 4:e202000941.
- Perez-Becerril C et al. (2022). Screening of potential novel candidate genes in schwannomatosis patients. *Hum Mutat.* 43:1368-76.
- Pramio DT et al. (2016). LINE-1 hypomethylation and mutational status in cutaneous melanomas. *J Investig Med.* 64:899-904.
- Rosales-Rodrigues B et al. (2021). Copy Number Alterations are Associated with the Risk of Very Early Relapse in Pediatric B-lineage Acute Lymphoblastic Leukemia: A Nested Case-control MIGICCL Study. *Arch Med Res.* 52:414-22.

P419 product history	
Version	Modification
B1	Two probes for <i>CDK4</i> have been replaced and one has been added, one probe for <i>CDKN2A</i> has been replaced, one probe for <i>CDKN2B</i> has been added, several reference probes have been replaced, and there are several differences in lengths but not in the sequences detected.
A2	Several probes have a small change in length, but no change in sequence detected.
A1	First release.

Implemented changes in the product description
Version B1-04 – 31 January 2023 (04P) - Paragraph about the positive samples updated with more detailed copy number alteration information on cancel cell line samples on page 3. - <i>CDKN2A</i> probe (16060-L31124) at 256 nt location updated in Tables 1 and 2: intron 1, instead of exon 1.

**Version B1-03 – 01 November 2022 (04P)**

- Product description rewritten and adapted to a new template.
- Exon numbering of the *CDKN2A* gene has been changed according to MANE.
- Ligation sites of the probes targeting the *CDKN2A*, *CDKN2B* and *MTAP* genes are updated according to new versions of the NM\_ reference sequences.
- Small changes of probe lengths in Table 1 and 2 in order to better reflect the true lengths of the amplification products.
- New references added on page 10.

**Version B1-02 – 07 June 2019 (01P)**

- Correction made to associate the proteins p16<sup>INK4a</sup> and p14<sup>ARF</sup>, encoded by the *CDKN2A* gene, to the correct transcripts (NM\_000077 and NM\_058195, respectively) on page 2 and 8.
- Various minor textual changes.

**Version B1-01 – 17 December 2018 (01P)**

- Product description adapted to a new product version (version number changed, changes in Table 1 and Table 2).
- Product description adapted to a new template.
- For uniformity, the chromosomal positions and bands in this document are now all based on hg18(NCBI36).

**Version 05 – 14 March 2016 (T08)**

- Various minor textual and layout changes.
- Schematic presentation 1 at page 7 has been updated to include alternative exon 4 of the NM\_001195132.1 transcript, and information about probes covering this alternative exon has been included in note III.

**More information: [www.mrcholland.com](http://www.mrcholland.com); [www.mrcholland.eu](http://www.mrcholland.eu)**

	MRC Holland bv; Willem Schoutenstraat 1 1057 DL, Amsterdam, The Netherlands
E-mail	<a href="mailto:info@mrcholland.com">info@mrcholland.com</a> (information & technical questions) <a href="mailto:order@mrcholland.com">order@mrcholland.com</a> (orders)
Phone	+31 888 657 200